



**NO PRE-LOAD
REQUIRED**

Chain will transmit through hoist, even without load.

OVERLOAD PROTECTION
Lever Hoist

Capacities from 0.8 up to 9 tonnes

APPLICATIONS:

This new robust Lever Hoist has many application choices for use in construction, engineering, forestry, automotive, offshore and underground mining when a safe reliable hoist with increased working load is needed.

Complies to AS1418.2

Meets or exceeds the following standards

ANSI B30.21

ANSI B30.16

Powder coated paint finish

All steel construction

Super strength plated alloy load chain

Integrated safety Overload Clutch

Weston brake with twin pawls

Stainless steel name plates

Minimum handle effort required to raise loads

Load chain includes enlarged end ring



Unique hand wheel & free wheel knob design.



Improved hook tips with cast self-locking latches.

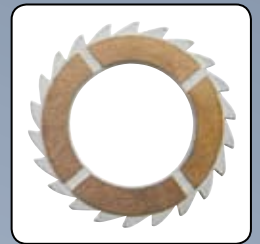

Innovative, patented friction disc with no brake discs required.



Caged roller bearings on the load sprocket.



Dacromet finish on the ratchet disc, cam, disc hub and change over disc.

Phosphoric surface treatment of the drive shaft.





OVERLOAD PROTECTION Lever Hoist WITH NO PRE-LOAD REQUIRED



PRODUCT SPECIFICATIONS & DIMENSIONS

Product Model Code		LSLH08	LSLH16	LSLH32	LSLH63	LSLH90
Capacity W.L.L.	tonnes	0.8	1.6	3.2	6.3	9.0
Load Chain falls		1	1	1	2	3
Load Chain Dia. x pitch	mm	5.6 x 15.7	7.1 x 19.9	10 x 28	10 x 28	10 x 28
Pull to lift rated load	N	215	303	372	382	392
Proof Load	kg	1200	2400	4800	9500	13500
Stand lift	m	1.5	1.5	1.5	1.5	1.5
Net weight	kg	5.7	8.0	13.6	26.0	40.0
Gross weight	kg	6.1	8.5	14.2	26.6	46.5
Extra weight per metre of chain	kg	0.7	1.1	2.3	4.7	7.0
Dimensions mm	a	146	164	196	196	196
	b	119	126	159	218	298
	c	41.5	52	61.9	84.3	-
	d	280	335	395	540	680
	e	245	265	415	415	415
	f	96	100	114	114	114
	g	26.5	35.5	43	53	64
	h	35.5	42.5	50	60	85
	i	14	19	24.5	34	40

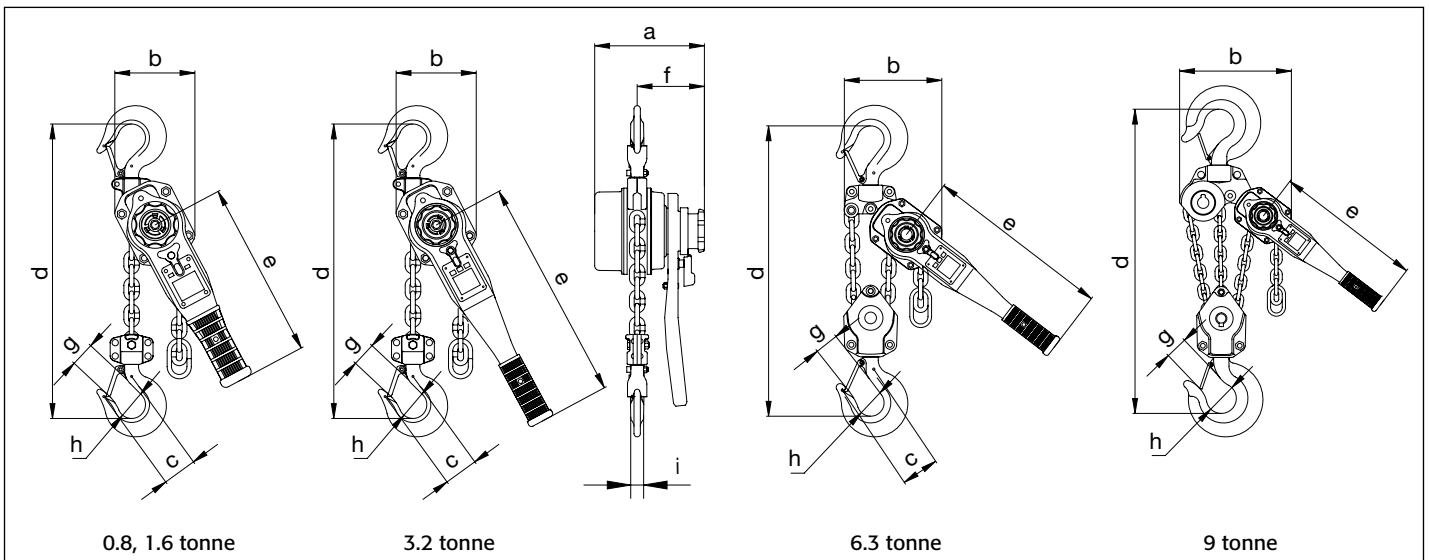

Designed by and manufactured for:
 Hoisting Equipment Specialists Pty Ltd
 31 Mangrove Lane
 Taren Point NSW 2229 Australia
 Phone: 1300 792 464
 Fax: 1300 309 041
www.hesnsw.com.au
www.ozblok.com.au



All Oz LoadSafe products are guaranteed against faulty workmanship or materials for a period of 5 years after the date of purchase.

