

LOADSAFE CHAIN HOISTS

Capacities: 500kg to 50 tonnes

FEATURES

- Lightweight robust construction
- Super strength alloy loadchain
- Fully machined liftwheel
- Minimum headroom
- Minimum effort to raise maximum load
- Cast steel safety latches
- Fully enclosed gear train
- Lower hook complete with trust race
- Weather protected automatic Weston brake with unique twin pawls
- Galvanised handchain as standard
- Durable baked enamel paint protection
- Stainless steel labels
- Spare parts always available

Loadsafe Chain Hoists are fitted with an overload - activated clutch which protects the operator from injury and the hoist from damage. Should an overload occur, the hoist will automatically stop transmitting the load, warning the operator to either reduce the load or select a hoist with a higher lifting capacity. Even when clutch is activated the load can be transmitted in the "DOWN" direction.

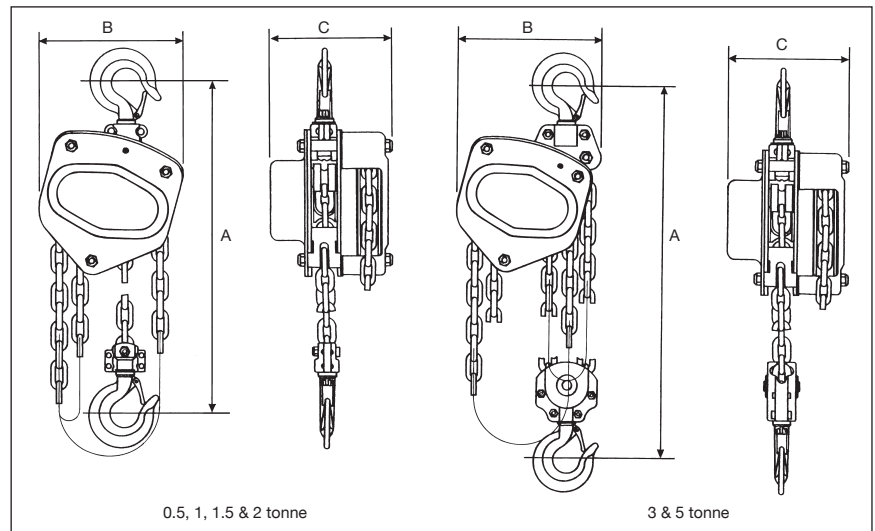

Product Code	SOCB05LS	SOCB1LS	SOCB1.5LS	SOCB2LS	SOCB3LS	SOCB5LS	SOCB10LS
Working Load Limit	0.5t	1t	1.5t	2t	3t	5t	10t
Standard lift	3m	3m	3m	3m	3m	3m	3m
Falls of chain	1	1	1	1	2	2	4
Effort to lift W.L.L.	23kg	30kg	32kg	35kg	27kg	41kg	39kg
Net weight	10kg	12kg	13kg	22kg	32kg	46kg	68kg
Loadchain diameter	6mm	6mm	8mm	8mm	8mm	10mm	10mm
CLEARANCE DIMENSIONS (mm)							
A (Headroom)	270	317	399	414	465	636	750
B (Width)	127	158	187	187	210	253	373
C (Depth)	131	140	161	161	161	161	184
Hook opening (upper)	30	28	36	33.5	40	50	64
Hook opening (lower)	30	28	36	33.5	40	50	64

COMPLIES WITH AS/NZS1418.2

Meets or exceeds all relevant world standards