

# Lifting & Hoisting

## Electric Chain Hoist

### Dual Speed Electric Chain Hoist

Designed for flexibility and durability, this economical, compact and lightweight dual speed electric chain hoist is ideal for assembly lines and workstations where precision and accuracy is required. Available in single or three phase with variable chain lengths, this robust dual speed electric chain hoist provides optimal safety and efficiency across a wide range of applications.

*Capacity:*  
0.25t to 1.0t

*Applications:*  
Automotive, Construction, Engineering, Logistics, Manufacturing, Mining.

*Complies with:*  
AS/NZS1418

#### Product Features

- Fivefold protected inverter control board.
- All aluminium alloy die cast hoist body, IP54.
- Dual speed constant torque inverter motor with overload protection.
- Gearbox with fully machined helical gears, case hardened, oil bath lubrication.
- Aviation plugs and sockets for constant conductivity, and elimination of plug falling off.



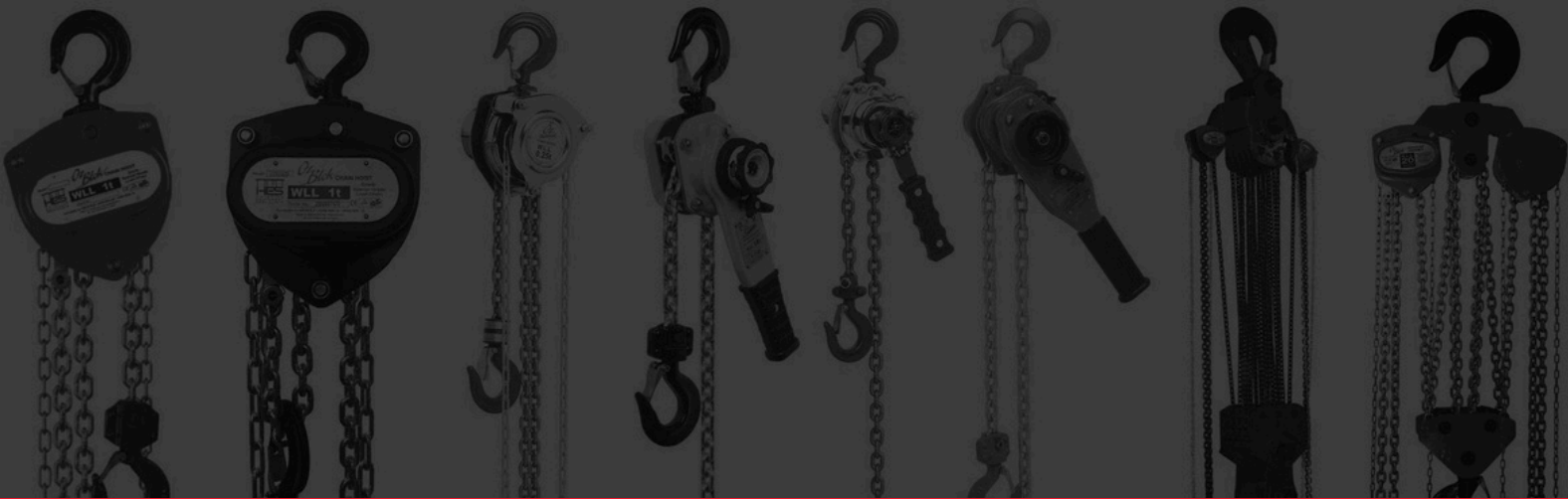

# Lifting & Hoisting

## Electric Chain Hoist

### SPECIFICATIONS

PRODUCT CODE	WORKING LOAD LIMIT (W.L.L.)	LIFTING HEIGHT (M)	WORKING LEVEL (ISO)	DUAL SPEED (M/MIN)	LOAD CHAIN (MM)	FALLS OF CHAIN	VOLTAGE (V/HZ)	DUTY CYCLE (FC%)	NET WEIGHT (KG)
ECHOZH002-1P	0.25t	3-6	M5	5/20	4x12	1	240	40	22
ECHOZH005-1P	0.50t	3-6	M5	1.5/6	5x15	1	240	40	23
ECHOZH010-3P	1.00t	3-6	M5	2/8	7x21	1	415	40	48

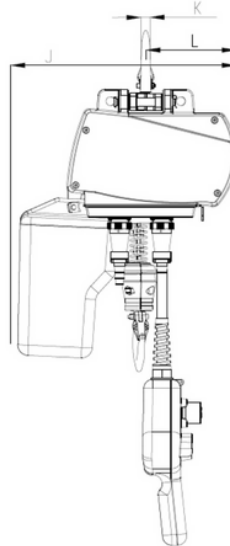
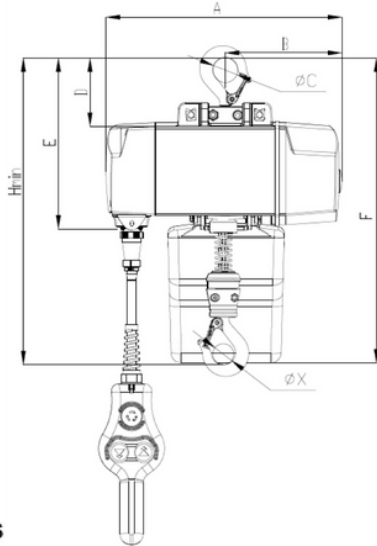

### DIMENSIONS

PRODUCT CODE	WORKING LOAD LIMIT (W.L.L.)	A	C	D	E	F	HMIN	K	X
ECHOZH002-1P	0.25t	345mm	24mm	102mm	233mm	450mm	382mm	13mm	24mm
ECHOZH005-1P	0.50t	345mm	27mm	113mm	244mm	461mm	424mm	16mm	27mm
ECHOZH010-3P	1.00t	458mm	35mm	127mm	313mm	578mm	569mm	22mm	35mm